

FEATURES

- Large active area
- Low noise
- High sensitivity
- Custom gains available
- Hermetically sealed TO-39

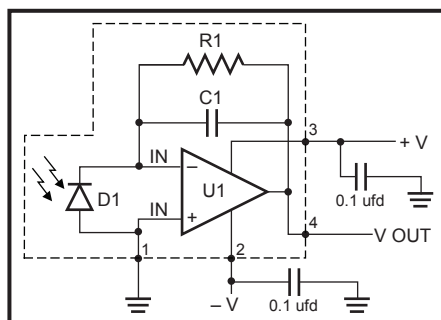

ELECTRO-OPTICAL CHARACTERISTICS AT 23°C

PARAMETERS	TEST CONDITIONS	MIN	TYP	MAX	UNITS
Dark Offset	$V_s = \pm 15\text{ V}$			± 1.0	mV
Dark Offset Noise	$V_s = \pm 15$ BW = 0.1 to 800 kHz		477	1000	$\mu\text{V rms}$
Sensitivity	$V_s = \pm 15$ $\lambda = 940\text{ nm}$	55	63		V/mW
Frequency Response (-3 db)	$V_s = \pm 15$ $\lambda = 940\text{ nm}$	500	800		kHz
NEP	$\lambda = 940\text{ nm}$		6.76		pW/√Hz
Transimpedance Gain			100		kΩ
Supply Current	$V_s = \pm 15\text{ V}$		6.2	7.5	mA

THERMAL PARAMETERS

Voltage Supplies	$\pm 5\text{ to } \pm 15\text{ V}$
Power Dissipation	225 mW
Storage and Operating Temperature	-25° to +100° C
Soldering Temperature (1/16" from case for 3 seconds max)	+260° C



1260 Calle Suerte, Camarillo, California 93012
 Phone: (805) 499-0335, Fax: (805) 499-8108
 Email: sales@optodiode.com, Website: www.optodiode.com

