



FEATURES

- Circular Active Area (4 Quadrants)
- TO-5, 5 Pin Package

Electro-Optical Characteristics at 25°C (Per Element)

Parameters	Test Conditions	Min	Typ	Max	Units
Active Area	R.049 [1.25 mm]		1.25		mm ²
Responsivity	(see graph on next page)				
Shunt Resistance, Rsh	V = ± 10 mV	100			MOhms
Capacitance, C	V _R = 0 V			500	pF
Response Time, tr	RL = 50 Ω, V _R = 0 V		1		µsec

Thermal Parameters

Storage and Operating Temperature Range	Units
Ambient	-10°C to 40°C
Nitrogen or Vacuum	-20°C to 80°C
Lead Soldering Temperature ¹	260°C

¹ 0.08" from case for 10 seconds.

Shipped with temporary cover to protect photodiode and wire bond.
 Review Opto Diode, "Handling Precautions for IRD Detectors", prior to removing cover.

Typical Photon Responsivity

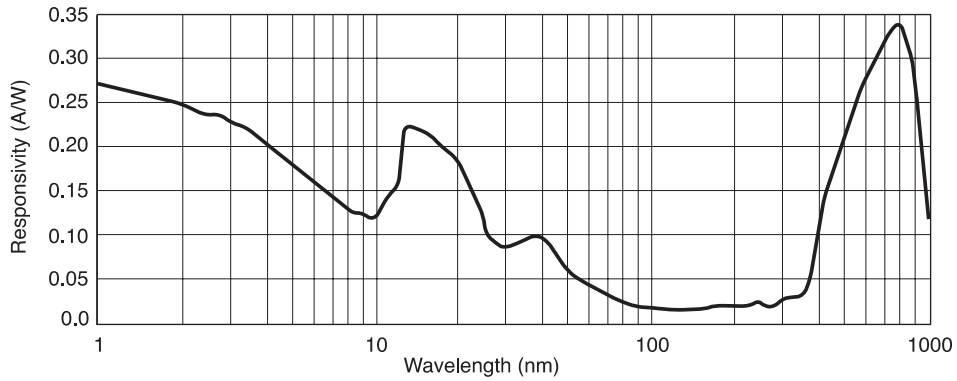

Package Information

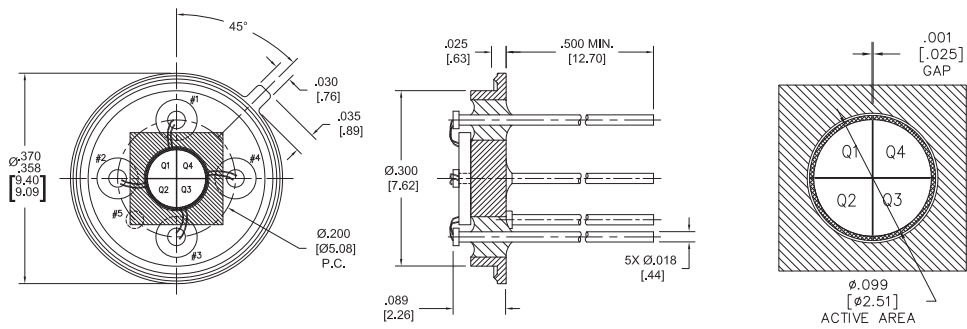

Dimensions are in inches [metric] units.

Specifications are subject to change without prior notice.